

K1

TPM CIRCLE NO: 2	ACTIVITY	KK	QM	PM	JH	SHE	OT	DM	E&T
TPM CIRCLE NAME: Joshile	LOSS NO. / STEP								
DEPT: Manufacturing Engineering	RESULT AREA	P	Q	DEF:-A	C	D	S	M	

KAIZEN IDEA SHEET

F/IMS/05

CELL: A467 CELL NAME: Tensioner Assy. MACHINE / STAGE: Pneumatic Press/Assembly OPERATION: Plug Pressing

KAIZEN THEME: To reduce RM cost of Jigs Fixture in A467 Tensioner Assy. @ Plug Pressing Stage.

WIDELY/DEEPLY:

PRESENT STATUS : Present plug pressing center locating Pin cost is INR 930/- Piece q

Discription : Plug Pressing Center locating Ping

Approx. Qty. Required/Year : 8 Nos

Cost Per Piece : INR 850/-

Average FS Jigs/Fix/ RM Cost/M : INR 7440/-

BEFORE

IDEA: To be separate top wear out & bottom fixed pin

COUNTERMEASURE : Made separate Piece of top wear out & bottom fixed pin & now after life over we are replacing top pin & cost of Top pin is INR 250/-

Discription : Plug Pressing Center locating Ping

Approx. Qty. Required/Year : 8 Nos

Cost Per Piece : INR 250/-

Average FS Jigs/Fix/ RM Cost/M : INR 2000/-

AFTER

BENCHMARK TARGET	INR 6800/-
KAIZEN START	04.10.17
KAIZEN FINISH	30.10.17
TEAM MEMBERS: N.S.Pujari & Mr. Murali	
BENEFITS: 1) Cost Saving per annum 4800/- 2) Changeover time reduce by 480 sec to 180 sec / time	

WHY - WHY ANALYSIS :-

Why1: Present plug pressing center locating Pin cost is INR 930/- Piece

Why2: Top Wear Out Part & Bottom Fixed Part In One Piece

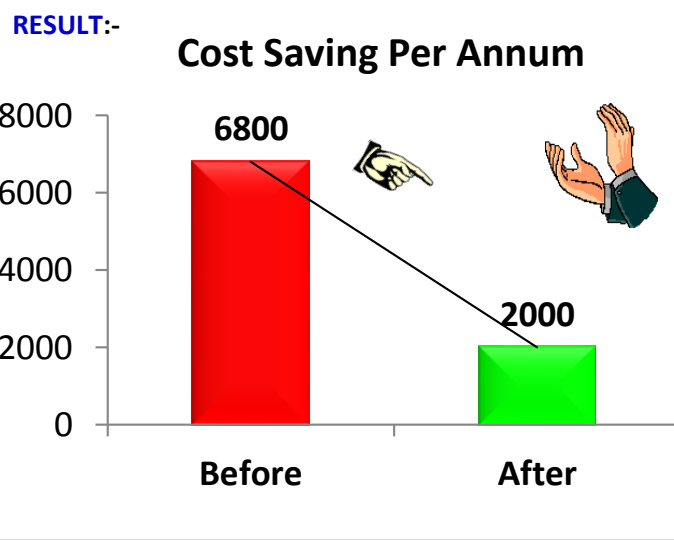

KAIZEN SUSTENANCE

WHAT TO DO : Fixture spare part to be update in line with revision & need to replace top pin only after life over

HOW TO DO : - Manual

FREQUENCY : On-Going Activity

COST INCURRED FOR MAKING KAIZEN

MATERIAL COST IN RS	LABOUR COST IN RS	TOTAL COST IN RS
-----	-----	-----

ROOT CAUSE:- Top Wear Out Part & Bottom Fixed Part In One Piece

REGISTRATION NO. & DATE: 1897 & 31.10.17

REGISTERED BY: Mr. Manas KP

MANAGER'S SIGN: Mr. N.S.Pujari

SCOPE & PLAN FOR HORIZONTAL DEPLOYMENT

SR. NO.	CELL	TARGET	RESP.	STATUS
1	A128/A157/A530	30.11.17	N.S.Pujari	Open

Success Celebration : Oct 17

Cost Kaizen : To reduce RM cost of Jigs Fixture in A467 Tensioner Assy. @ Plug Pressing Stage

Kaizen by : Mr. N.S Pujari & Mr. Murali

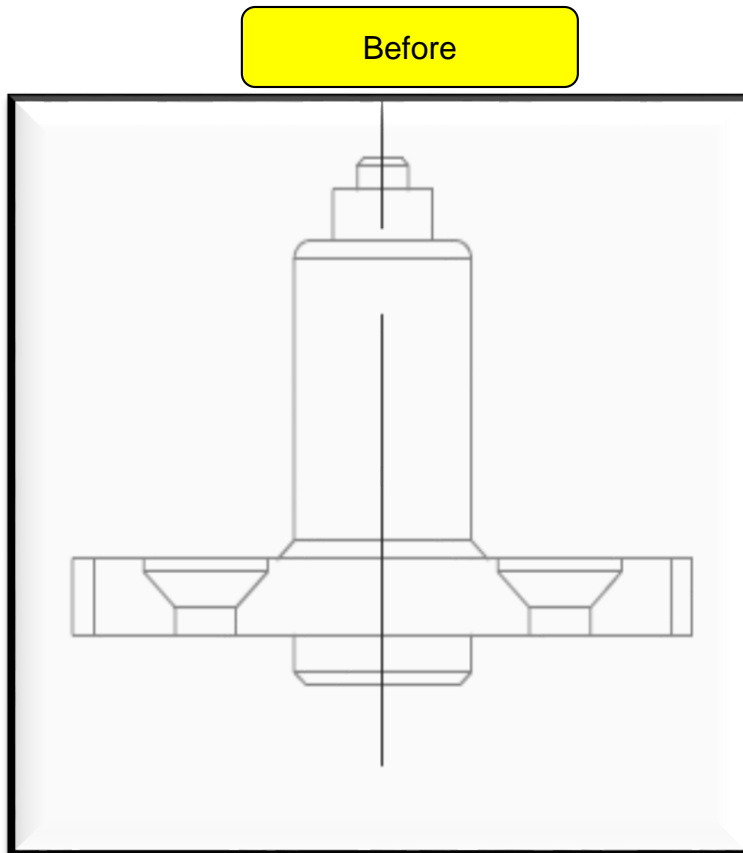

A467 Tensioner Assy. Plug Pressing Centre
Locating Pin- Top Wear Out Part & Bottom
Part In One Piece- Need to replace full centre
locating pin after life over

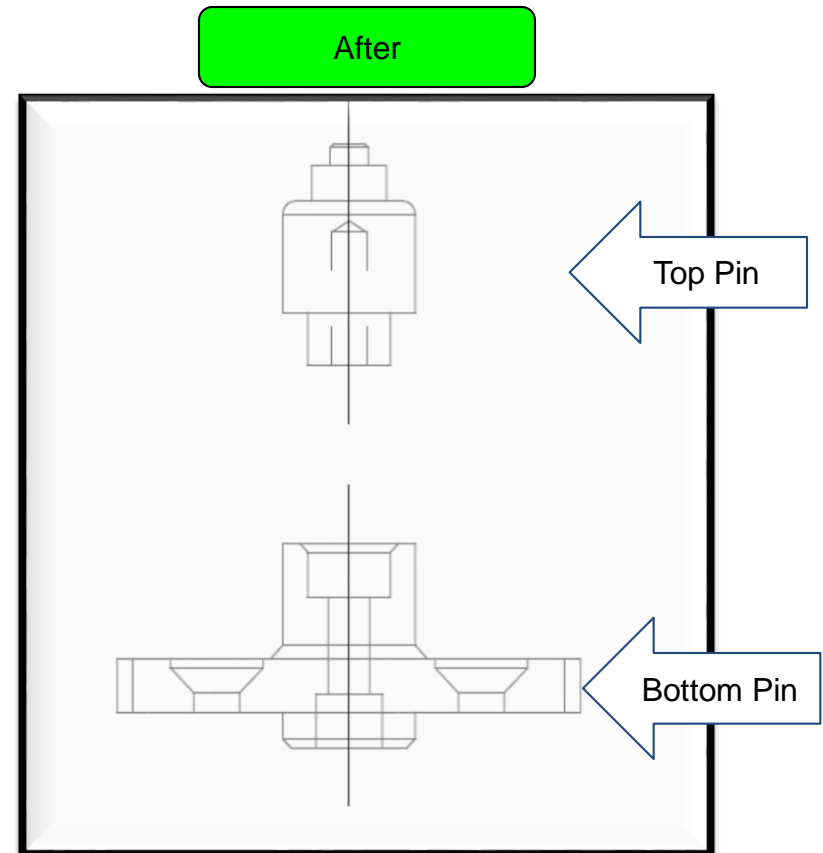

A467 Tensioner Assy. Plug Pressing Centre
Locating Pin- Top Wear Out Part & Bottom
Fixed Part Separate ,Need to replace full Top
Pin only after life over